

Low-intensity L810 Solar Aviation Obstruction Light

AH-LS-L



This LED Low-intensity Solar Powered Aviation Obstruction light is adopting insert high efficient solar panels integrated design, cooperate with solar dedicated lithium ion battery as power supply. Built-in photocell ensure LED only working at night and closed in the daytime automatically.

It is designed for marking top of obstacle that do not exceed 45 meters in height.

Compliance

- CAO Annex 14 Volume 1, Sixth edition, 2013, table 6.3 Low Intensity Type A / B Obstruction Light
- FAA L-810

Features

Electrical

- LED as light source, life experience >100,000hours

Physical

- With bird needle to prevent bird drop
- UV & vibrations protected polycarbonate lens for converging light
- Powder coated die casting aluminum base, light fastness, resist snow and rain
- Built-in mono crystalline silicon solar panel, conversion efficiency is better than poly crystalline silicon

System design

- Built-in photocell (Photo diode) for day & night working mode (dusk to dawn mode)
- ON/OFF button make local control easy
- Flashing(20fpm)/steady toggle switch under base

Optional

- Infrared LED for pilot using NVG(Night Vision Goggles)

Application

- AH-LS-L solar low-intensity light is specialized used on the top of the High Chimney, Telecommunication tower, Wind Turbine where there is no cable power supply and those facilities which have high requirements on lightning protection.
- Used alone on the top of obstacle which height is less than 45meter



APPLICATION



Low-intensity L810 Solar Aviation Obstruction Light

AH-LS-L

Dimension(mm)

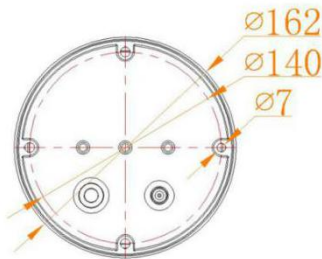

Installation

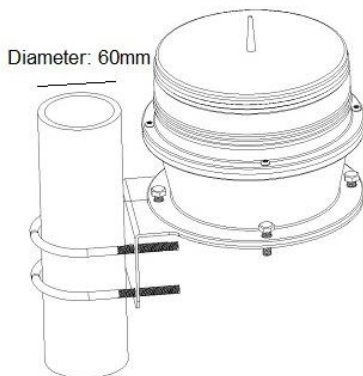

(Mounting bracket is charged separately,
and size is customized)

SPECIFICATIONS

AH-LS-L Low-intensity L810 Solar Aviation Obstruction Light

Light Characteristics

Light Source	LED
Emitting Color	Red
Intensity(cd)	10cd(Steady), 32.5cd(Flashing)
Horizontal Output(degrees)	360
Vertical Divergence(degrees)	≥10
Flash Characteristics	Steady/Flashing(20fpm) adjustable
Operation Mode	Dusk-to-Dawn operation
LED Life Experience(hours)	>100,000

Electrical Characteristics

Operating Voltage	3.7
Circuit Protection	Integrated

Solar Characteristics

Solar Module Type	Mono crystalline Silicon
Output(watts)	1.8
Charging Regulation	Microprocessor controlled

Battery Characteristics

Battery type	Lithium ion battery
Nominal Voltage (V)	3.7
Battery Service Life	Average 3 years
Autonomy (hours)	Steady: 60, Flashing: 120

Physical Characteristics

Lamb Body Material	UV protected Polycarbonate
Base Material	Powder-coated Die-casting aluminum
Installation Size	140×140×M6
Overall Size (mm)	162×162×160
Weight(kg)	1
Product Life Expectancy	Average 5 years

Environmental Factors

Ambient Temperature(°C)	-55~70
Humidity	0~100%
Wind Speed	80m/s
Waterproof	IP68

Compliance

ICAO	Annex 14 Volume 1, 'Aerodrome Design and Operations' Sixth edition July 2013, table 6.3 Low-intensity Type A/B Obstacle Light
FAA	L-810

Optional

NVG - compatible infrared (IR) LED